

## MB 12/5 T4 0,06KW (MB123456)

### GENERAL DATA



#### MEDIUM PRESSURE CENTRIFUGAL FAN WITH FORWARD IMPELLER

##### MANUFACTURING FEATURES:

- Rolling steel sheet housing.
  - Completely joined or welded housing.
  - Galvanised steel sheet simple inlet forward curved impeller.
  - Polyester powder finishing coat.
  - Standard asynchronous squirrel-cage motor with IP-55 protection and Class F insulation.
- Manufactured with standard voltages: 230V 50Hz in single phase motors and 230/400V 50Hz in three phase motors.

- Available positions (to be indicated in case of order): LG270, LG0, LG45, LG90, LG135, LG180, LG225, LG315, RD0, RD45, RD90, RD135, RD180, RD225, RD270, RD315.
- The indicated codes correspond to the model in position LG270

##### APPLICATIONS:

Designed for inline installation, they are suitable for:

- Industrial applications, extraction or injection of air.
- Cooling of machines and parts.
- Suitable for transporting totally clean air without dust.
- Maximum working temperature: carried air: 130°C, environment single phase 50°C, three phase 60°C.

##### UNDER REQUEST:

- Special voltages.
- 2 speed motors (three phase motors).
- Fan for air working temperatures up to 250°C.
- Fans provided with cooling disk for high temperature.
- Option with support for models where it is not included, and without support for models where it is included.

## PERFORMANCE CURVE

20 °C - m - 1.2 Kg/m<sup>3</sup>

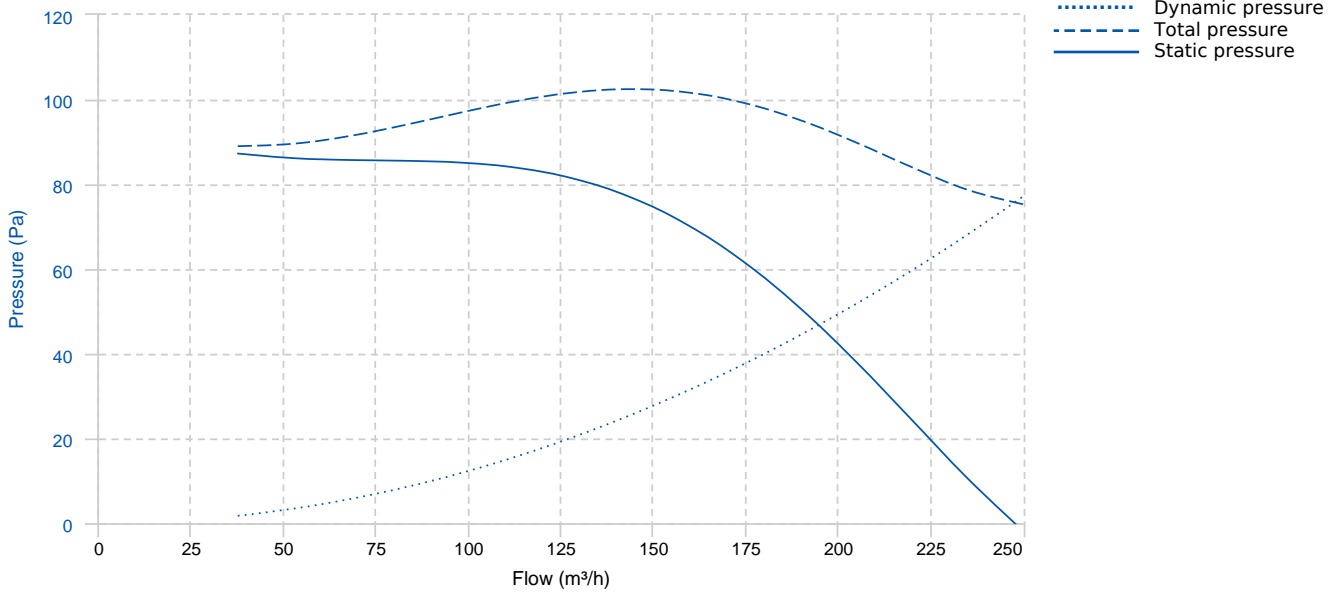

## TECHNICAL DATA

Fan							
RPM	1400	Approx. weight	5 kg	Max. Flow	250 m³/h		
Motor							
Power	0,06 kW	RPM	1400	I max. (230V)	0,47 A	I max. (400V)	0,27 A
Size	56	Approx. weight	3 kg				

## DIMENSIONS

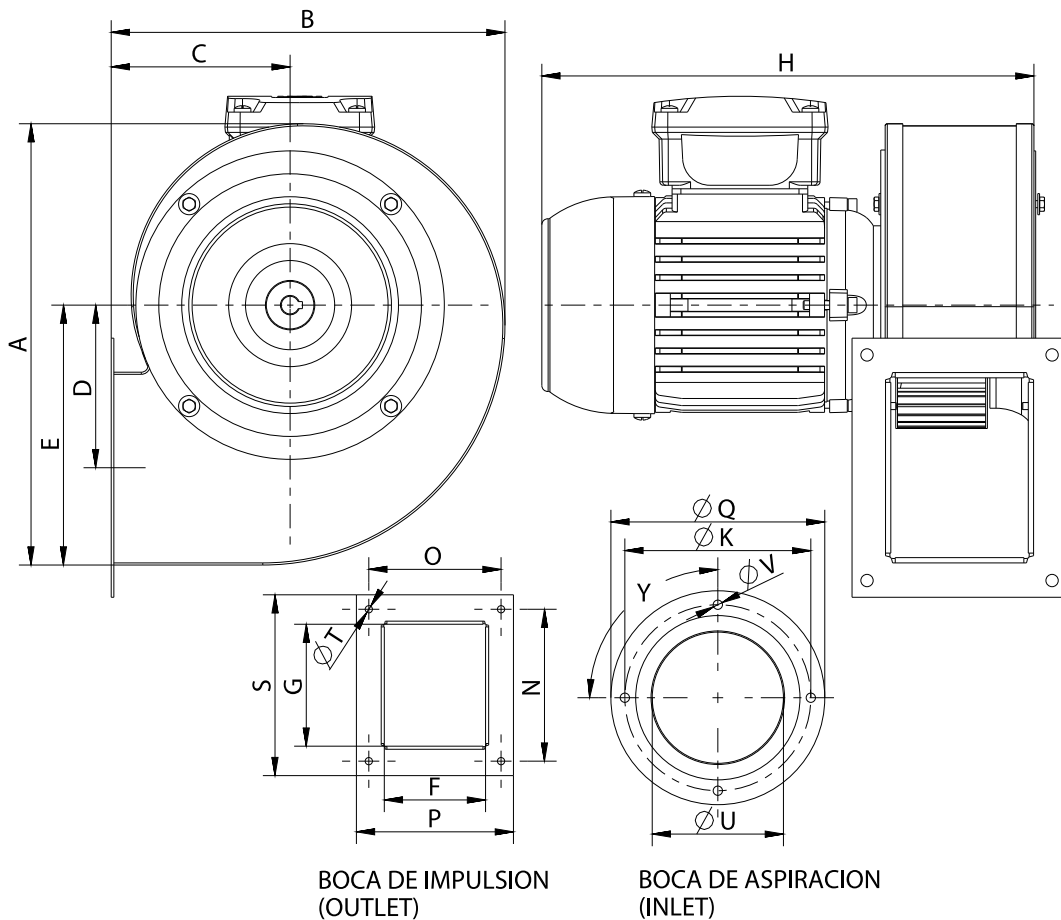

### Dimensions (mm)

A	205,5	B	187	C	87	D	71,5	E	117
F	72	G	81,7	H	251	K	135	N	105
O	93	P	106	Q	150	S	118	TØ	7
UØ	92,5	VØ	7	Y	4x90°				

### WIRING DIAGRAM

230V 

400V 

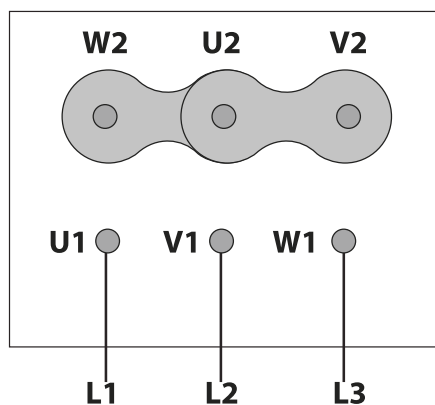
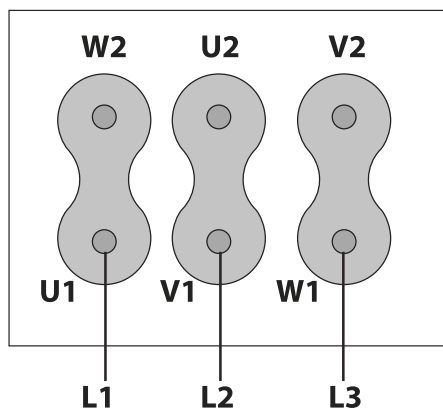

**SPARE PARTS**

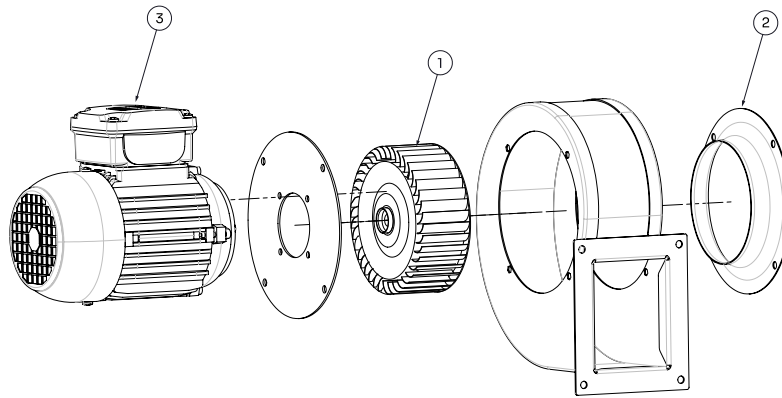

	Code	Model	Qty
3	721001100	MOTOR 0,08kW T4 B14 230/400V	x1